

SHOCKSTOP SEATPOST

INSTRUCTIONS

Thanks for choosing the Redshift Sports ShockStop Suspension Seatpost! The seatpost provides tunable suspension to increase comfort and performance during your ride.

This seatpost is different than other seatposts, so please read these instructions and warnings completely before installing or using the seatpost. If you are unfamiliar with bike maintenance or seatpost installation, or if you lack the required tools, please visit your local bike shop or contact Redshift Sports customer service for assistance (support@redshiftsports.com). Improper installation or use may void the product's warranty.

Check out www.redshiftsports.com/faq for instructional videos and additional resources.

COMPATIBILITY

This seatpost is designed for bicycle frames with a 27.2mm diameter circular seat tube. The seatpost may be used with larger diameter seat tubes by using the correct diameter seatpost shim. In order to reduce stresses on the post and frame, only use seatpost shims of at least 100 mm (4 in.) in length. Using the seatpost in a different diameter seat tube without an appropriate shim may cause damage or failure of the seatpost or bicycle frame.

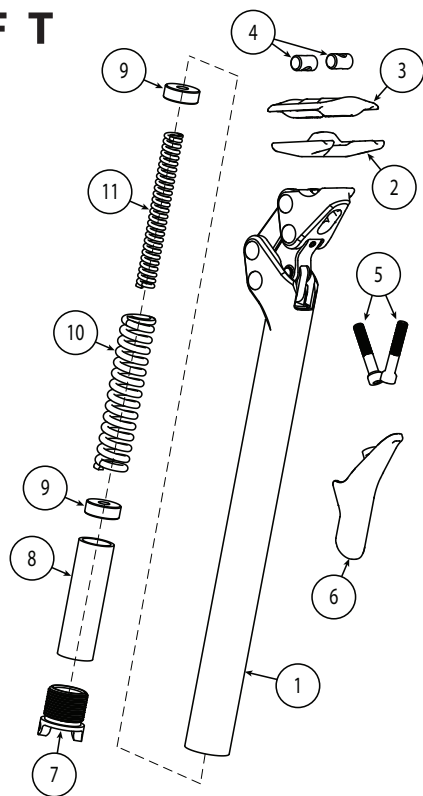

#	QTY	PART NAME
1	1	Seatpost & Linkage
2	1	Lower Saddle Clamp
3	1	Upper Saddle Clamp
4	2	Saddle Clamp Nuts
5	2	Saddle Clamp Bolts
6	1	Fender
7	1	Preload Adjustment Plug
8	1	Spring Spacer
9	2	Spring Endcap
10	1	Main Spring
11	1	Inner Spring (Optional)

CHOOSING YOUR SEATPOST SETUP

The Shockstop seatpost is fully adjustable to fit you and your riding preference. Different springs can be used to make large adjustments to the stiffness, and then fine-tuning can be accomplished by adjusting the preload plug located at the bottom of the seatpost.

The chart shown here is a good starting point, but different riders may prefer stiffer or softer settings than the chart recommends. Riding position and terrain can also dramatically affect the required preload setting, so don't be afraid to experiment with different settings to find your best ride!

RIDER WEIGHT	SPRING SETUP	SUGGESTED INITIAL PRELOAD
< 110 lb / 50 kg	Main Spring Only	1
132lb / 60 kg	Main Spring Only	2
154 lb / 70 kg	Main Spring Only	3
176 lb / 80 kg	Main Spring Only	4*
198 lb / 90 kg	Main + Inner Spring	2
220 lb / 100 kg	Main + Inner Spring	3
242 lb / 110 kg (max)	Main + Inner Spring	4

*When using the Main Spring Only, the maximum recommended preload setting is 4. Riders needing more preload should add the Inner Spring and start at a lower preload setting.

CHANGING SPRINGS

The ShockStop Seatpost ships with 2 springs – an outer spring which comes pre-installed in the seatpost, and an inner spring which is included in the package.

NOTE: THE OUTER SPRING MUST ALWAYS BE INSTALLED. The inner spring can be optionally added when a stiffer spring rate is desired.

1. Remove seatpost from frame.
2. Turn seatpost upside-down and completely unscrew the preload plug. This can be done by hand or by inserting a 4 mm hex wrench through the side holes in the plug to provide additional leverage.
3. Tilt seatpost to slide internal components out the bottom of the seatpost: spring spacer, spring(s) and spring end caps.
4. Insert or remove the inner spring inside the outer spring
5. Apply grease to the outside of the outer spring and spring end caps, if needed.
6. Turn seatpost upside-down again and reinstall the internal components, noting the order in the picture. The protective material around the outer spring should be oriented towards the top of the seatpost. The spring end caps should be sitting flat against the spring. When fully installed, the spacer tube should sit a few millimeters inset from the bottom of the seatpost. If the spacer tube is protruding from the bottom of the post, make sure the suspension linkages are fully extended and make sure the spring end caps are sitting flat against the spring.
7. Re-install preload plug and adjust as-needed for desired suspension firmness.

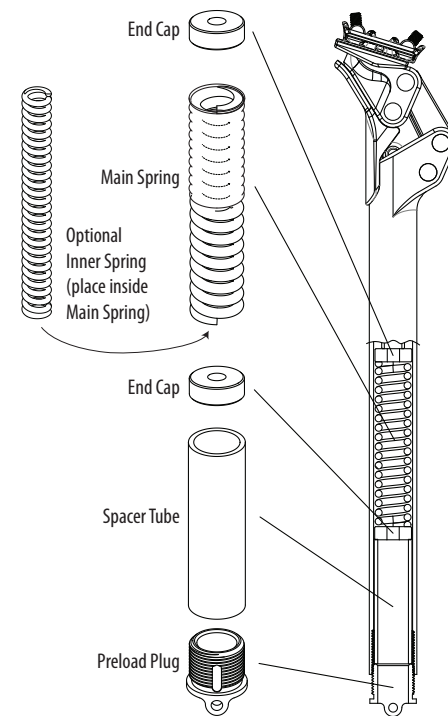

NOTE: The ShockStop Seatpost Di2 Battery Holder Accessory (sold separately) will allow you to securely mount a Di2 battery in the bottom of the seatpost.

⚠ WARNING

- Failure to follow these instructions and warnings may result in malfunction or breakage of this component, possibly causing serious injury or death.
- Always use a torque wrench when installing or adjusting fasteners, and always tighten to Redshift torque specifications (or the bike manufacturer's torque specification). Periodically check all fasteners for tightness using a torque wrench, since fasteners can loosen under the influence of road vibration.
- This seatpost is designed for use in a 27.2 mm diameter seatpost. It may be used with larger seat tube diameters by using an appropriate diameter shim longer than 100mm (4 in.) in length.
- Do not raise the post beyond the minimum insertion line.

- Periodically clean and inspect all surfaces of this component for hairline cracks or signs of damage. If you find any cracks or damage, immediately cease using the part and contact Redshift Sports customer service.
- This seatpost is intended for road and light off-road use only. It is NOT intended for extreme off-road use or jumping. Unintended use may lead to breakage of the component, possibly causing serious injury or death.
- Never place your hands or fingers near the seatpost linkages while riding. Doing so may cause pinching or crushing injuries.
- For metal-framed bicycles, ensure that the post and the inside of the seat tube are covered with a thin layer of bicycle grease prior to installation. Failure to do so may cause the post to seize inside the bicycle frame.

SETTING THE PRELOAD

A preload adjustment of “1” is the softest setting. Turning the preload plug further into the seatpost will increase the stiffness and firm up the suspension. This can be done by hand, or if necessary, a 4mm hex wrench can be inserted through the side holes in the plug to provide additional leverage. The firmest setting is with the preload plug turned all the way in (it does not need to be tight).

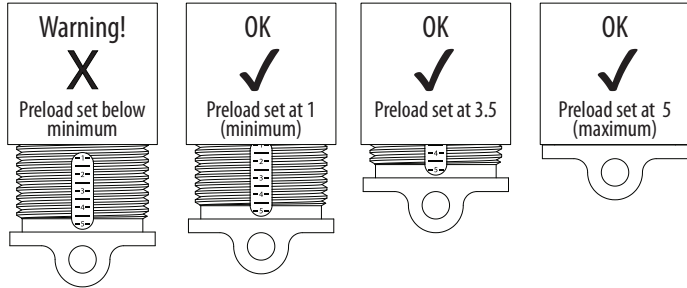

WARNING! DO NOT SET THE PRELOAD ADJUSTMENT BELOW THE “1” MARK. DOING SO CAN CAUSE INTERNAL PARTS TO LOOSEN OR FALL OUT WHILE RIDING.

As a general guideline for a comfortable setting, set the preload so that the suspension mechanism moves down approximately 6mm (20%) from the top of its travel range when you are sitting in a neutral riding position. The 20% sag point can be determined visually by removing the fender and observing the linkage pivot shaft from the side (it may be helpful to enlist the help of a friend). Adjust the preload setting such that the end of the silver pivot shaft is barely (but completely) hidden from view by the side of the post when you are seated in a neutral riding position.

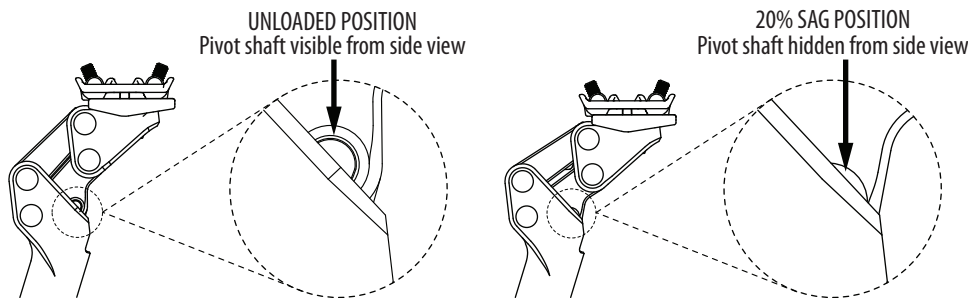

Another general guideline is the “bounce test”. While riding on flat ground, raise up off the saddle and then sit down with some force to bounce the suspension. If it’s easy for you to reach the full range of travel and you’re getting a noticeable “bottom-out” feel at the end of travel, you may want to increase the preload.

WARRANTY

Redshift Sports LLC warrants that this product is free from defects in material and workmanship for two years from the date of original retail purchase. This warranty applies to the original retail purchaser only, and is not transferable to any subsequent purchaser(s). At their discretion, Redshift Sports will repair or replace the defective product with the same model (or an equivalent model if an identical model is unavailable). This warranty does not cover components that are damaged due to improper installation, improper adjustment, poor maintenance, crashes, abuse, modification, misuse, or other conditions deemed abnormal or excessive by Redshift Sports LLC.

All warranty returns must be accompanied by a Return Authorization Number (RA#) and dated proof-of-purchase. You can obtain an RA# by submitting a warranty claim at www.redshiftsports.com or by emailing returns@redshiftsports.com.

INSTALLING THE SEATPOST

STOP! THE SHOCKSTOP SEATPOST MUST BE SET UP WITH THE APPROPRIATE PRELOAD ADJUSTMENT AND/OR SPRING COMBINATION BEFORE INSTALLING. SEE ‘CHOOSING YOUR SEATPOST SETUP’ AND ‘SETTING THE PRELOAD’ SECTIONS FIRST!

NOTE: TO ACCOUNT FOR SUGGESTED 20% SAG (THE INITIAL SUSPENSION TRAVEL WHEN YOU SIT DOWN), YOUR SADDLE SHOULD BE POSITIONED 6 MM HIGHER AND 5 MM FURTHER FORWARD THAN YOUR SADDLE POSITION WHEN USING A RIGID SEATPOST.

1. Prior to removing your existing post, you may wish to measure and record the existing height, fore-aft position, and tilt angle of your saddle for future reference.
2. Remove your existing seatpost and saddle. Clean the inside of the bicycle’s seat tube and ensure that the inside of the seat tube is free of burrs and sharp edges. Apply a thin layer of grease to the inside of the seat tube. DO NOT grease seat tubes of carbon frames unless specified by the frame manufacturer.
3. Insert the seatpost into your bicycle seat tube to the approximate desired height. Do not twist the seatpost during insertion. Ensure that the seatpost is inserted far enough into the seat tube that the minimum insertion line on the seatpost is not visible above the frame’s seatpost clamp.
4. Tighten the bicycle’s seatpost clamp bolt according to the bicycle manufacturer’s torque specification.
5. Use a 4mm hex wrench to loosen the saddle clamp bolts until the threads are barely engaged in the nuts. Install the saddle between the upper and lower clamp. Some saddle rail shapes may require the bolts to be fully unthreaded from the nuts to install the saddle.

NOTE: POSITION LOWER CLAMP WITH LONGER RAIL SUPPORTS TOWARD THE BACK OF THE SADDLE

6. If installing the seatpost fender, completely remove rear saddle clamp bolt from the nut, loop fender o-ring around bolt under the upper saddle clamp, and reinstall bolt as shown in the picture.

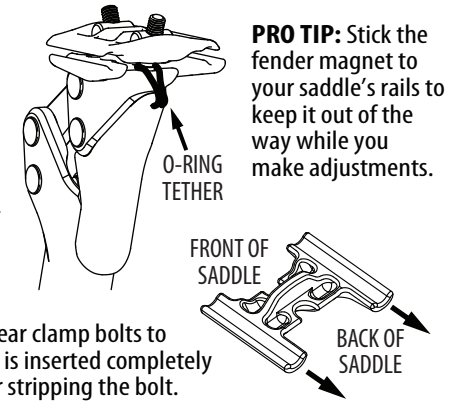

7. Use a 4mm hex wrench to lightly tighten the front and rear clamp bolts to hold the saddle in place. Make sure that the hex wrench is inserted completely into the hex hole in the bolt heads to avoid damaging or stripping the bolt.
8. Position the saddle in the desired fore-aft position within the saddle clamp.
9. Use a 4mm hex wrench to adjust the saddle angle by tightening or loosening the front or rear saddle clamp bolts. Once the desired saddle angle is achieved, alternately tighten both bolts in quarter turn increments, using a torque wrench for the front bolt and a standard hex wrench for the rear bolt. Stop tightening both bolts once the front bolt reaches 6 N-m of torque. Do not exceed 9 N-m.

WARNING! ADJUSTING THE SADDLE CLAMP TILT BEYOND ITS RANGE MAY DAMAGE THE SEATPOST: WHEN TIGHTENING THE REAR BOLT (TILTING REARWARD), THE UPPER SADDLE CLAMP MUST NOT BE IN CONTACT WITH THE REAR PORTION OF THE LINKAGE MECHANISM.

WHEN TIGHTENING THE FRONT BOLT (TILTING FORWARD), THERE MUST BE A GAP OF AT LEAST 2MM BETWEEN THE UPPER SADDLE CLAMP AND THE UPPER LINKAGE.

WARNING! DO NOT OVER TIGHTEN SADDLE CLAMP BOLTS! OVERTIGHTENING MAY LEAD TO SEATPOST FAILURE, POTENTIALLY CAUSING SERIOUS INJURY OR DEATH. ALWAYS USE A TORQUE WRENCH WHEN ADJUSTING SADDLE CLAMP BOLTS.

11. Install fender against rear linkage by placing the fender magnet on the front saddle clamp bolt.
12. Adjust saddle height if necessary.

MAINTENANCE

The ShockStop Seatpost is designed to run quietly and smoothly with minimal maintenance. If you encounter any issues with your seatpost, please visit redshiftsports.com/faq for instructional videos and troubleshooting help, or contact us at support@redshiftsports.com.

NOTE: DO NOT USE GREASE OR ANY LUBRICATION ON PIVOT BUSHINGS. THEY ARE DESIGNED TO RUN DRY AND WILL PERFORM BETTER AND LAST LONGER WITH NO LUBRICANT.